

Frigidaire

INTERNATIONAL

**FACTORY
PARTS CATALOG**

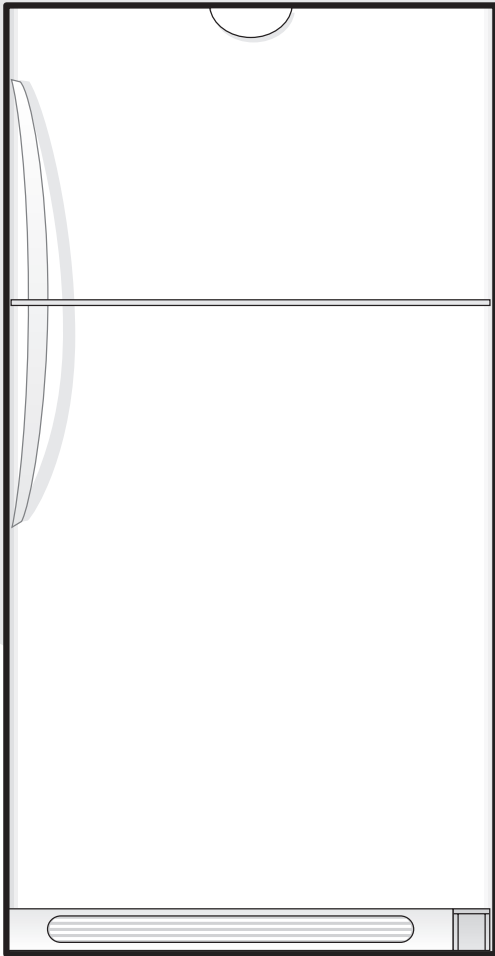

PRODUCT NO.	BASE MODEL NO.	SERIES	COLOR	VOLTS
FGTD20V4AW2	FGTD20V4A	134A SYSTEM	white	220
MARKET				
INTERNATIONAL				

WIRING DIAGRAM - 240459901
OWNER'S GUIDE - 240432700
SERVICE DATA SHEET - 240459901

International

3 Parkway Center
Pittsburg, PA 15220

**TOP MOUNT
REFRIGERATOR**

**Model No.
FGTD20V4A**

Publication No.
5995380739
021104
-EN/SERVICE/KHB
390

DOOR

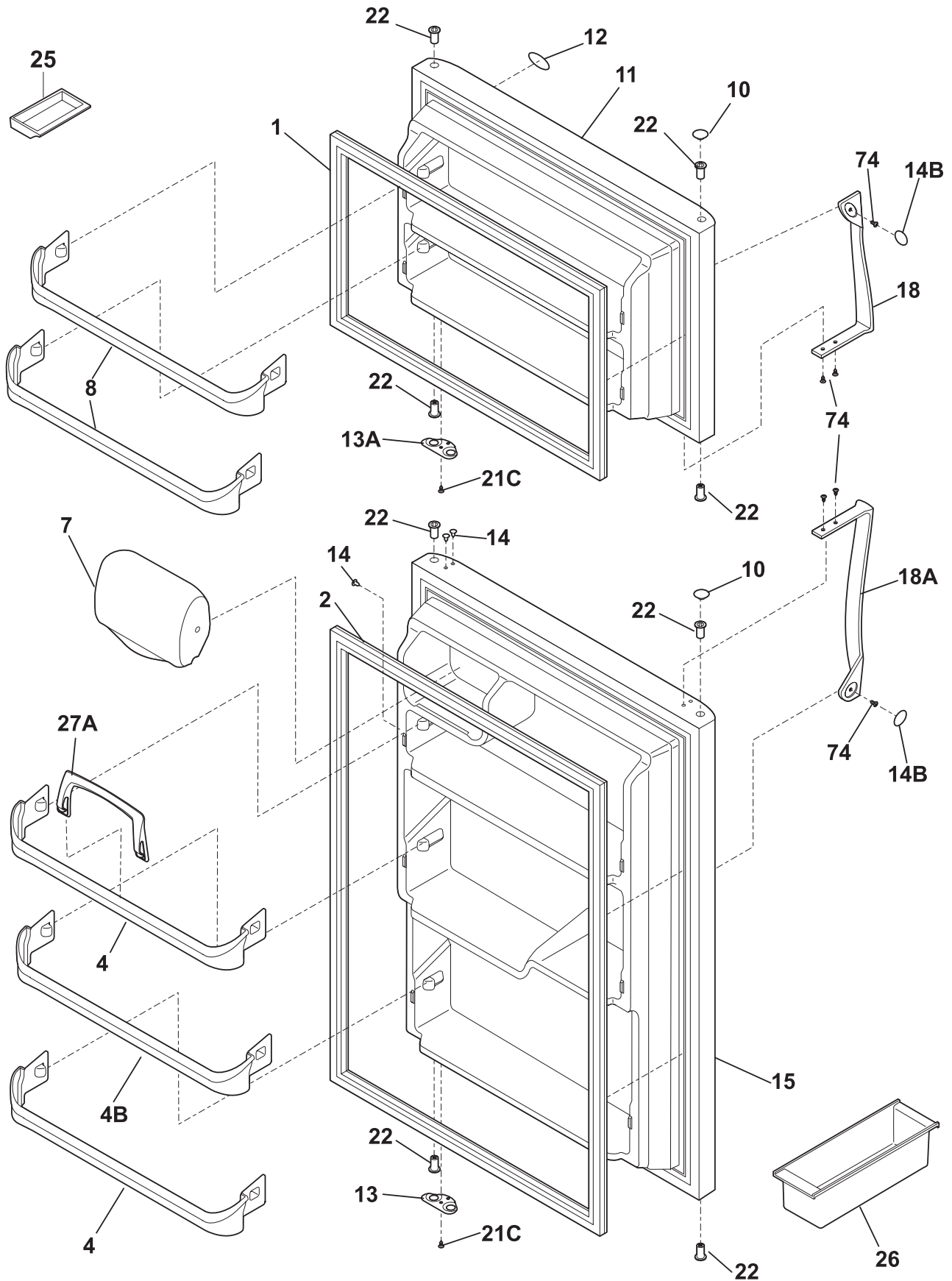

N05DCDCKA1

DOOR

POS. NO	PART NO	DESCRIPTION
1 #	240542103	Gasket-frzr door,white ,magnetic
2 #	240542106	Gasket-refr door,white ,magnetic
4	240534901	Rack-door
4B	240534701	Rack-door,4B
7	240337703	Door-dairy,w/o graphics ,clear
8	240534801	Rack-door
10	240381301	Plug-button,white ,hinge brg hole ,(2)
11	240409901	Panel-frzr door,white ,complete assy
12	240416301	Label-nameplate,white
13	240312403	Door Stop,white ,ref
13A	240312404	Door Stop,white ,frzr
14	240494001	Plug-button,white
14B	240383601	Plug-button,white ,door handle
15	240410001	Panel-refr door,white ,complete assy
18	240339201	Handle-door,white
18A	240339206	Handle-door,white
21C	218252200	Screw,#8 truss hd ,10-32CA x 0.500
22	240527101	Bearing-hinge,natural color ,(8)
25	5308000716	Dish,butter
26	3204522	Container,egg
27A	240396102	Retainer,tall bottle
74	240383401	Screw,truss hd quad ,#10-16 x .500

CABINET

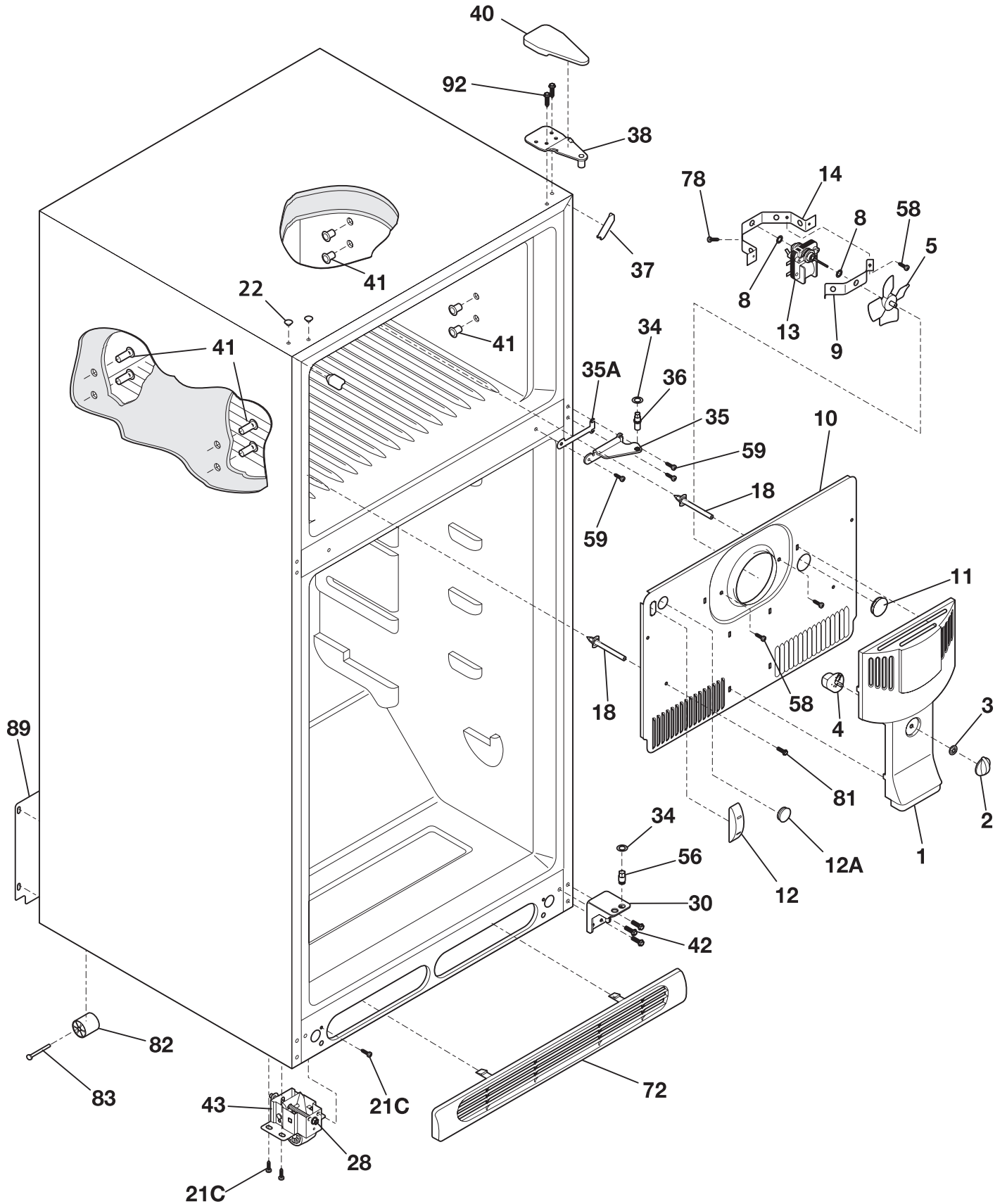

N05BBAABA0

CABINET

POS. NO	PART NO	DESCRIPTION
1	240355401	Cover-fan
2	240367001	Knob-damper control
3	5303001028	Nut,push-on
4	240367401	Damper-fan cover
5 #	5308000010	Fan Blade,red ,evaporator fan
8	5300157666	Bushing-motor mtg,(2)
9	5303292396	Bracket-motor mtg,front
10	240462008	Cover-evap coil
10*	240532102	Seal-coil cover
10*#	240524701	Wiring Harness,freezer section
11	5303208309	Plug-hole,factory test
12	240366801	Plug-ice maker harness,rectangular
12A	240374401	Plug-wtr inlet tube,round ,1"
13 #	240419701	Motor,evaporator fan ,220/240 V
13*	218931001	Clamp-motor wiring,nylon, w/adhesive tape
14	5303292397	Bracket-motor mtg,rear
18	240411901	Support-evap cover,(2)
21C	218252200	Screw,#8 truss hd ,10-32CA x 0.500
22	215774901	Plug-button,white ,upr hinge holes
28	240335501	Bolt-roller adj,hex wshr hd,1/4-20 x 4.020, (2), special
30	240314002	Bracket-lower hinge,white
34	240311301	Washer,hinge ,nylon ,(2)
35	240313802	Bracket-ctr hinge,white
35A	240336801	Spacer-hinge,center
36	240516401	Pin-center hinge
37	240337601	Trim-cabinet corner, white, (2)
38	240313701	Bracket-upper hinge
40	240354401	Cover-upper hinge,white
41	5303001609	Grommet,shelf mtg ,0.69" ,RH
41*	5308009759	Grommet,shelf mtg ,1.25" ,LH
42	240423601	Screw-hinge mtg,hex head ,1/4-20 x 0.75
43	240335003	Roller Assy,front ,(2)
56	240516501	Pin-lower hinge
58	5303001343	Screw,hex washer head ,8-15A x 0.500
59	240442702	Screw-#10-32 X 3/4,white
72	240368205	Grille/Kickplate,white
78	241500301	Screw, hex washer head, 8-18AB x 0.500
81	5308016566	Screw, hex washer head, 8-15A x 0.625, low profile
82	5304418225	Roller,compressor base ,rear ,(2)
83	5303316859	Rivet,flat head ,1/4 OD x 1-3/4, roller pin
89	240326119	Cover-access,with label
89*	241500302	Screw,hex washer head ,8-18AB x 0.625
92	5303001479	Screw-hinge mtg,hex hd ,1/4-20 x 0.875
*	240542601	Clip-wiring harness
*	5303305324	Paint,touch-up ,white

SHELVES

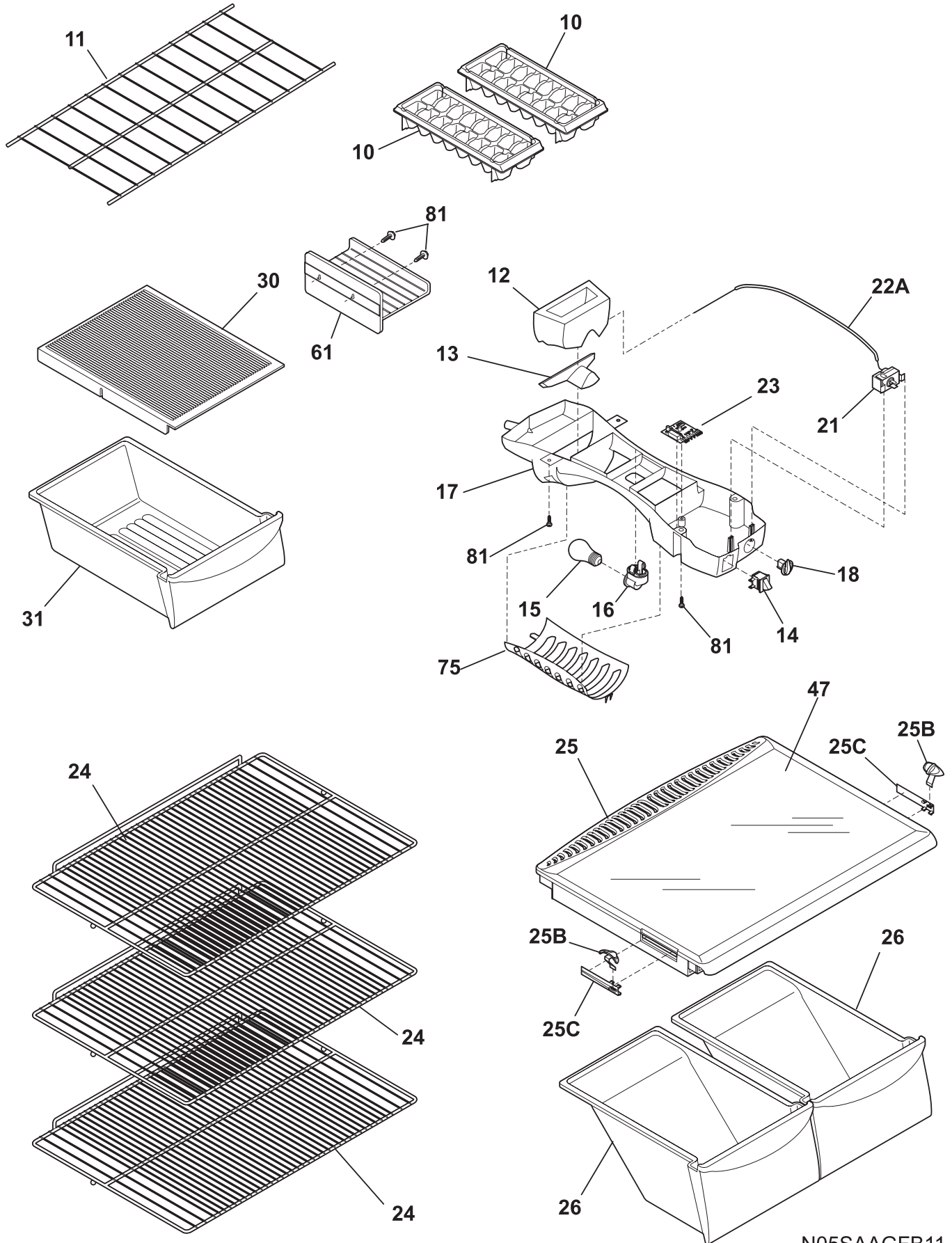

N05SAAGFB11

SHELVES

POS. NO	PART NO	DESCRIPTION
10	215667501	Tray,ice cube ,plastic
11	240358002	Shelf-freezer,full width
11*	5303299664	Spacer,shelf
12	240545001	Diffuser,air ,top
13	240362601	Diffuser,air ,bottom
14 #	240505801	Switch,light/lamp
15	218814400	Light Bulb/Lamp
16	240433702	Socket-light/lamp
17	240352701	Control Box
17*#	240375501	Wiring Harness,control box
18	240360801	Knob,temp control
21 #	5304422638	Control,temperature
22A	240468201	Tube, sensor sleeve, 31 inch, plastic, white
23 #	240545402	Control-defrost, adaptive timer, 220/240 V, PC board
23*	5303001259	Screw-timer mtg, pan hd, 6-20 x 0.438, (2)
24	240360905	Shelf,sliding ,wire
25	240364714	Cover-crisper pan
25B	240361201	• Control-humidity
25C	240361301	• Damper,humidity cont.
26	240337103	Pan-crisper,clear ,(2) ,no graphics
30	240361801	Cover,meat pan hanger ,drop through
31	240530803	Pan-meat,w/o graphics ,clear
47	240350643	Insert-pan cover,glass
61	215781501	Shelf,ice tray mount ,wire
75	240412701	Shield,light
81	5308016566	Screw, hex wshr hd, 8-15A x 0.625, low profile

SYSTEM

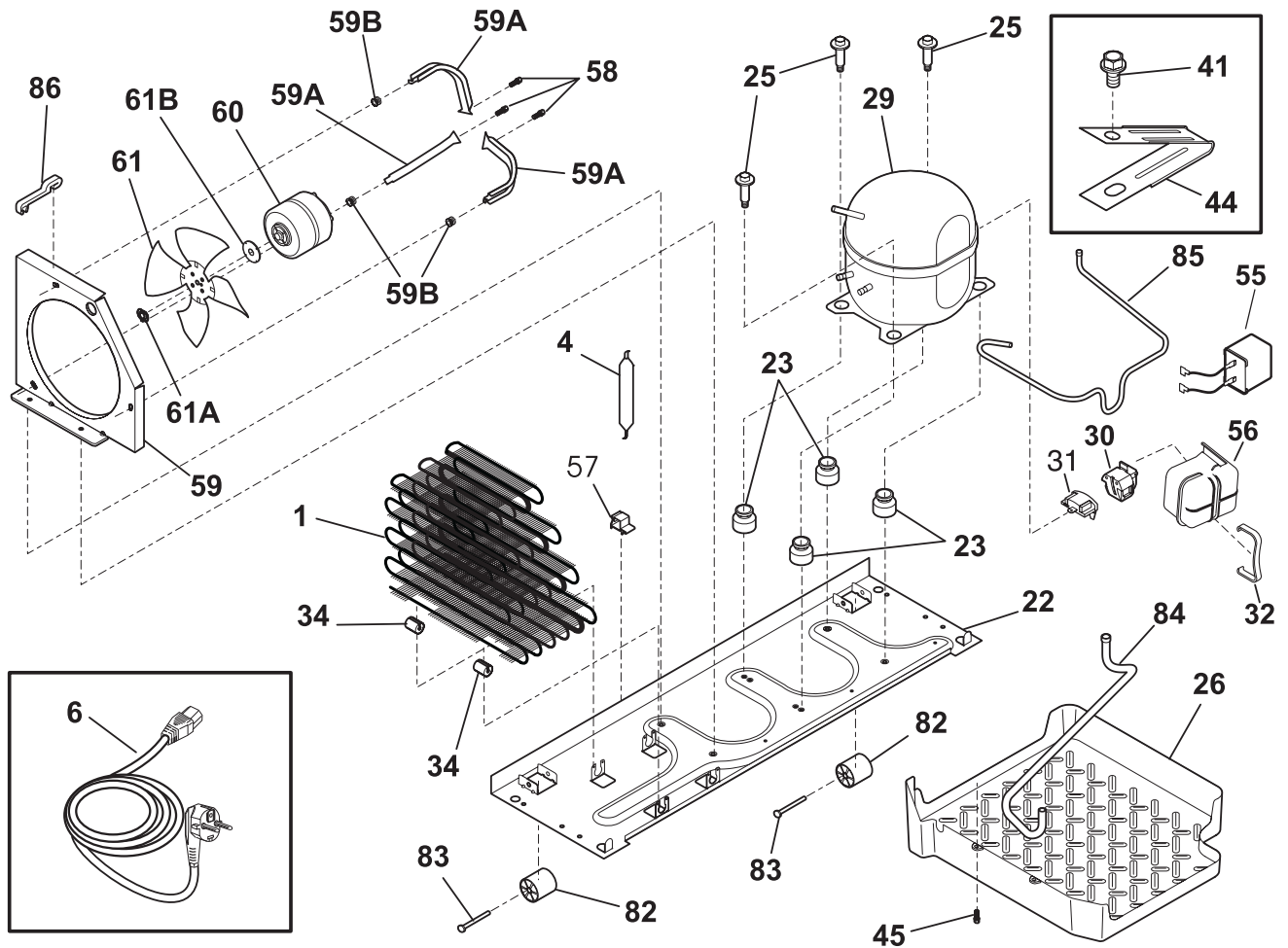
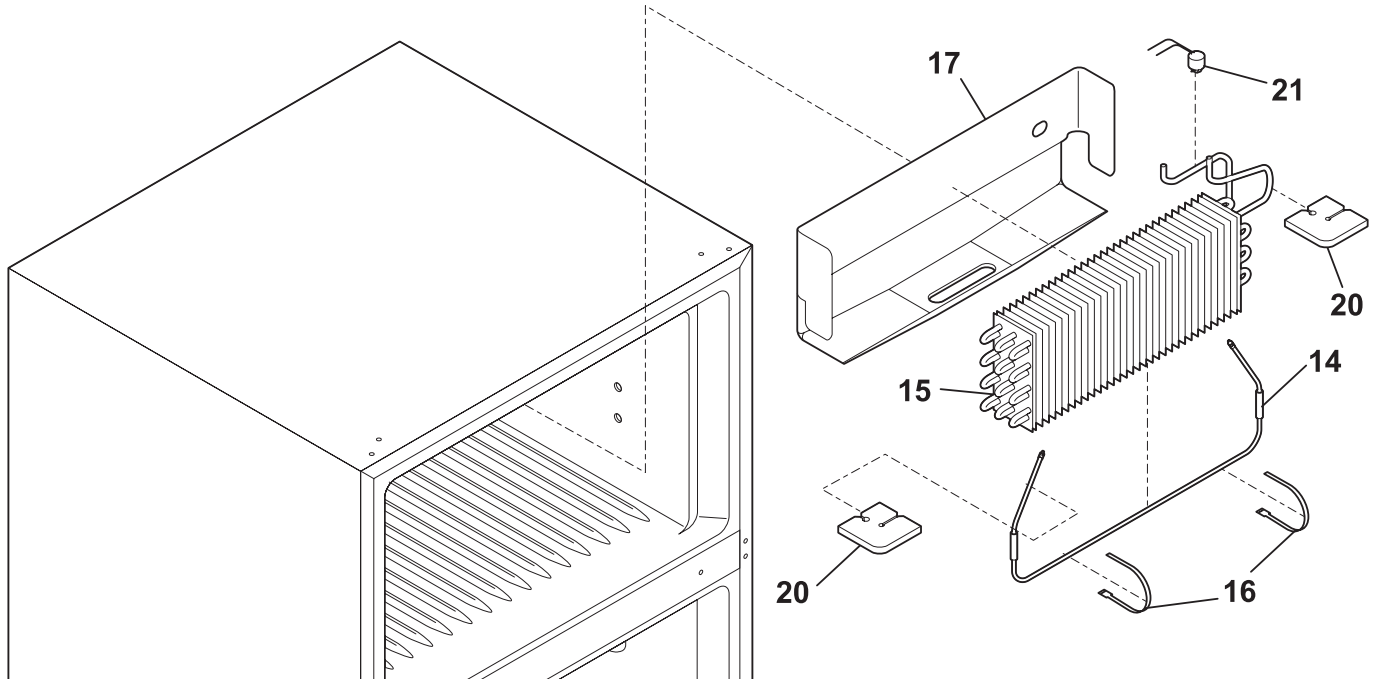

N05CABABA1

SYSTEM

POS. NO	PART NO	DESCRIPTION
1	240444401	Condenser,dynamic
4 #	218944001	Drier-filter,R134a System
6 #	240449501	Cord-electric power
6*	240447101	Bracket,strain relief
6*	240447201	Clamp,strain relief
6*	240451501	Screw, ind hex wshr hd, 8-32 x 0.375, thread rolling
6* #	240375501	Wiring Harness,control box
6* #	240524701	Wiring Harness,freezer section
6* #	240525501	Wiring Harness,machine compt
14 #	5303918240	Defrost Heater Kit,220 V
15 #	5303918274	Evaporator Kit
16	5308000110	Strap-evap/heater,aluminum ,(2)
17	240434002	Trough-drain
20	240518401	Insulation,evap block ,foam ,LH/RH
21 #	5303918202	Thermostat-defrost,kit
22	240330001	Plate-compr mtg
22*	218252200	Screw,#8 truss hd ,10-32CA x 0.500
23	218513300	Grommet-compr mtg,(4)
25	240491501	Screw-compressor mtg, 1/4-28 x 1.16, shoulder, typ CF
26	240332605	Pan-defrost drain
29 #	5303918237	Compressor,w/electricals
30 #	5303309882	Relay
31 #	5304422635	Overload Protector,220/240 V
32	5303006412	Strap-cover mtg
34	240405201	Grommet,rubber ,black ,cond tube/wire
41	218897001	Screw,hex washer head ,8-32 x 1/4
44	5303001199	Clamp-wiring harness, strain relief, galv steel
45	5308016566	Screw, hex wshr hd, 8-15A x 0.625, low profile
55 #	218909906	Capacitor-run, 350-400 VAC, 7.5 microfarad,13.5"wire leads
56	08006982	Cover-terminal
57	240542601	Clip-wiring harness
58	215004600	Screw,hx serr wshr hd ,8-36 x 7/16, cond fan motor,(2)
59	240315501	Shroud-cond fan
59*	240346701	Tape-foam seal,shroud
59*	240359401	Screw-fan shroud,(2)
59A	240346501	Bracket-support,cond mtr ,(3)
59B	240346601	Grommet-bracket,(3)
60	240419801	Motor,condensor fan
61 #	240315401	Fan Blade,galv steel ,condenser fan
61A	215004700	Nut,speed
61B	215004800	Grommet-silencer
82	5304418225	Roller,compressor base ,rear ,(2)
83	5303316859	Rivet, flat hd, 1/4 OD x 1-3/4, roller pin
84	240500801	Tube-drain,rubber ,lower
85	240346201	Tube-connector,suction
86	240409302	Spacer-cond tube,black
*	218843800	Screw,hex wshr hd ,8-15A x 0.500
*	240396801	Clamp,tube/wiring ,nylon ,black/natural
* #	5303918263	Heat Exchanger Kit,suction line
* #	5303918241	Hot Tube Repair Kit,220 V ,Service

WIRING SCHEMATIC

LADDER SCHEMATIC—TM DYNAMIC MODELS

NOTE:
- - - - - DENOTES NOT ON ALL MODELS.

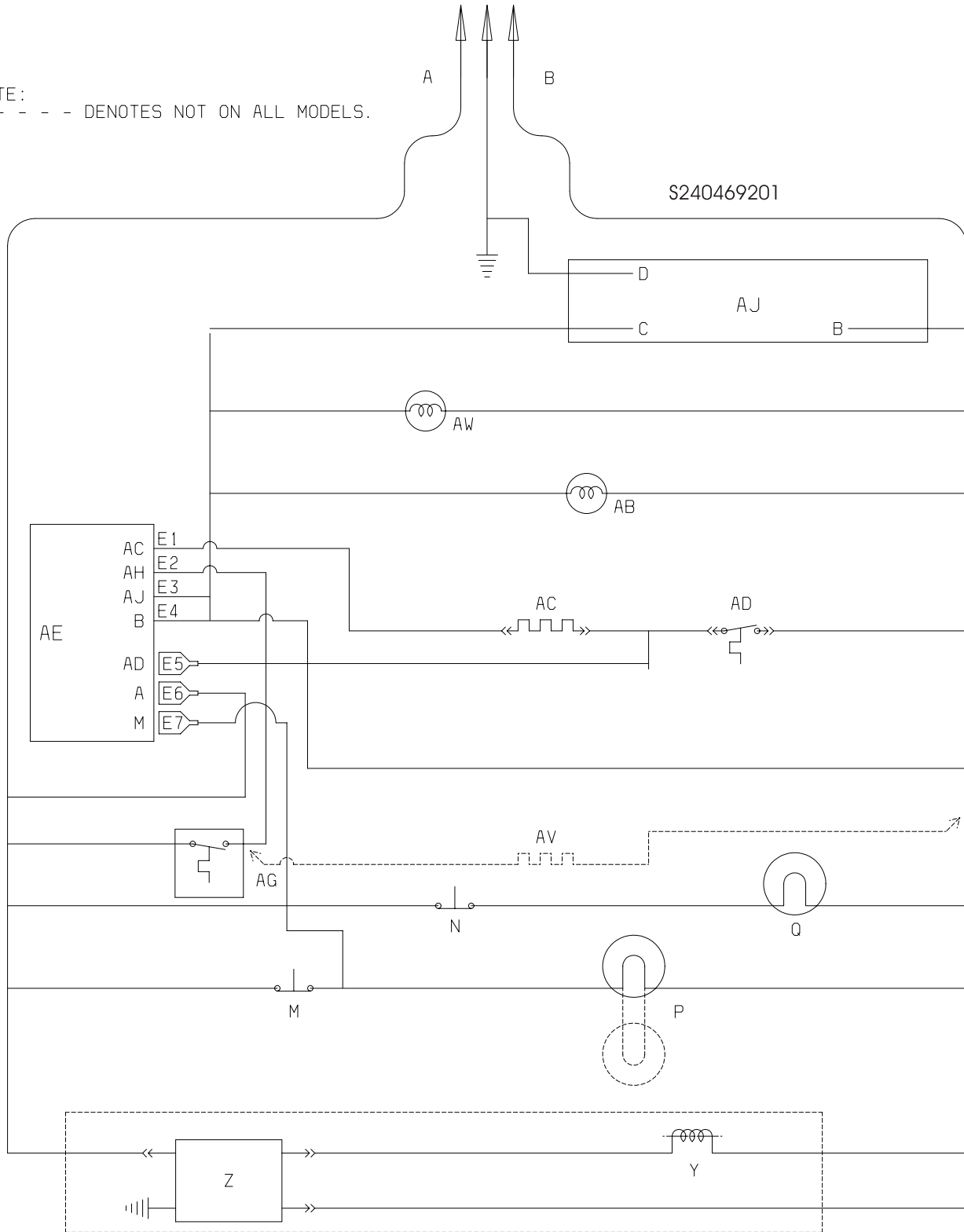

WIRING DIAGRAM

